

SECTION 1: Answer **one** question from this section.

Question 1

A sketch of a hammer and peg toy is shown on the right. The toy consists of a frame, three pegs and a hammer.

- (a) In the space below, complete to a scale of 1:2 the following orthographic views of the **frame** of the toy.
- (i) A front view in the direction of **FE**. [4]
 - (ii) An end view in the direction of **EE**. [2]
 - (iii) A plan in the direction of **P**. [5]
- Do **not** show any hidden detail.
- (b) Add **three** dimensions to the orthographic views. [2]
- (c) Add the projection symbol in the box provided. [2]

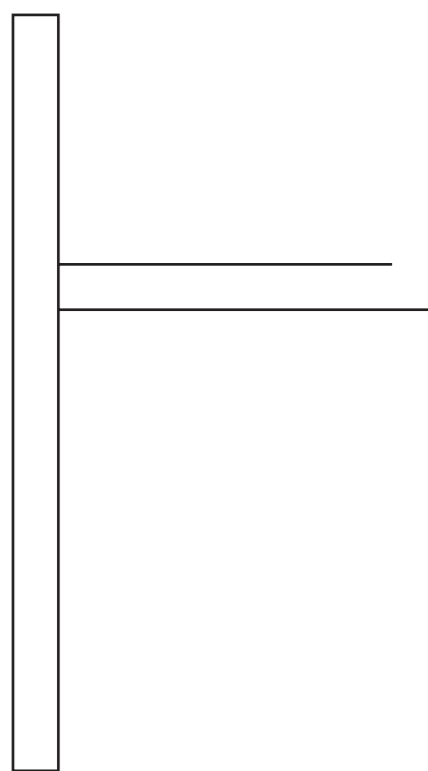
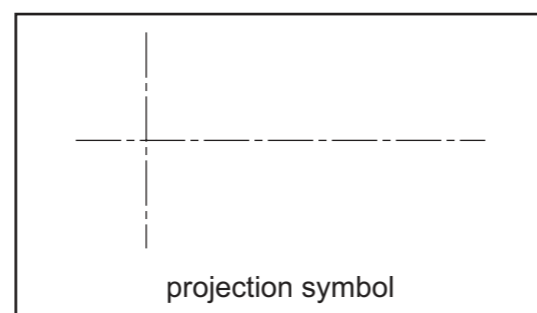
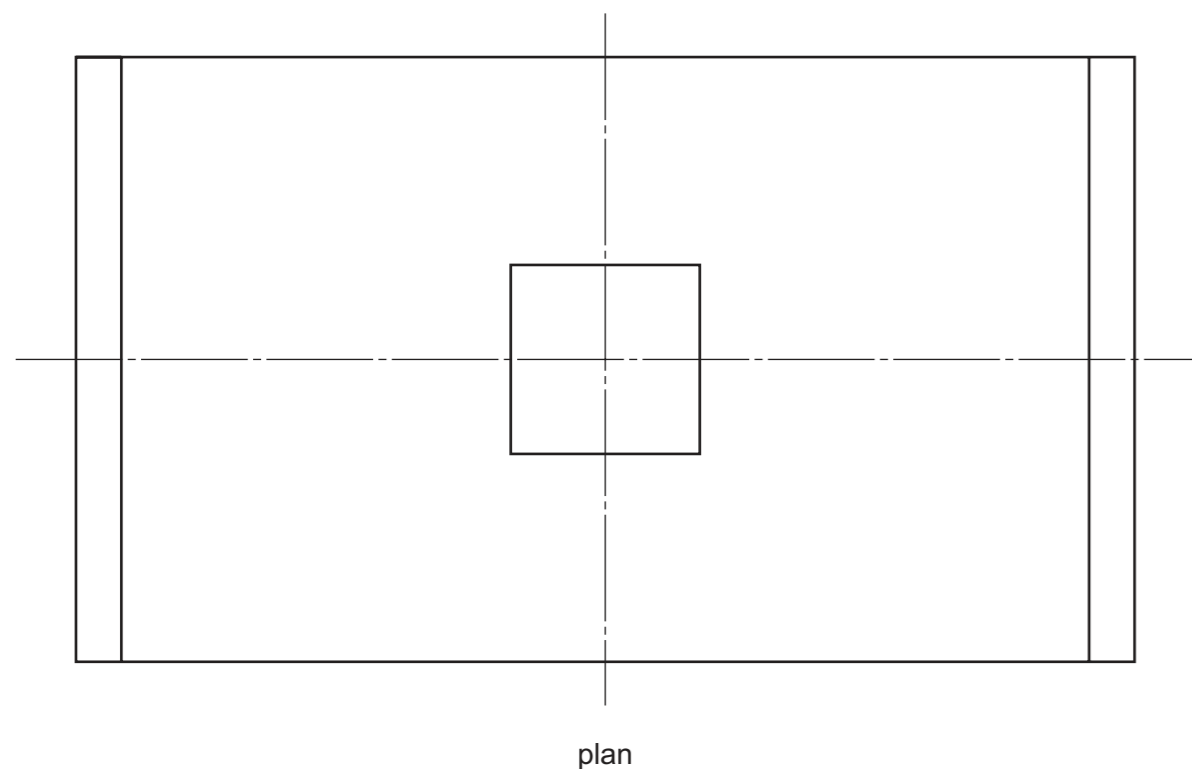
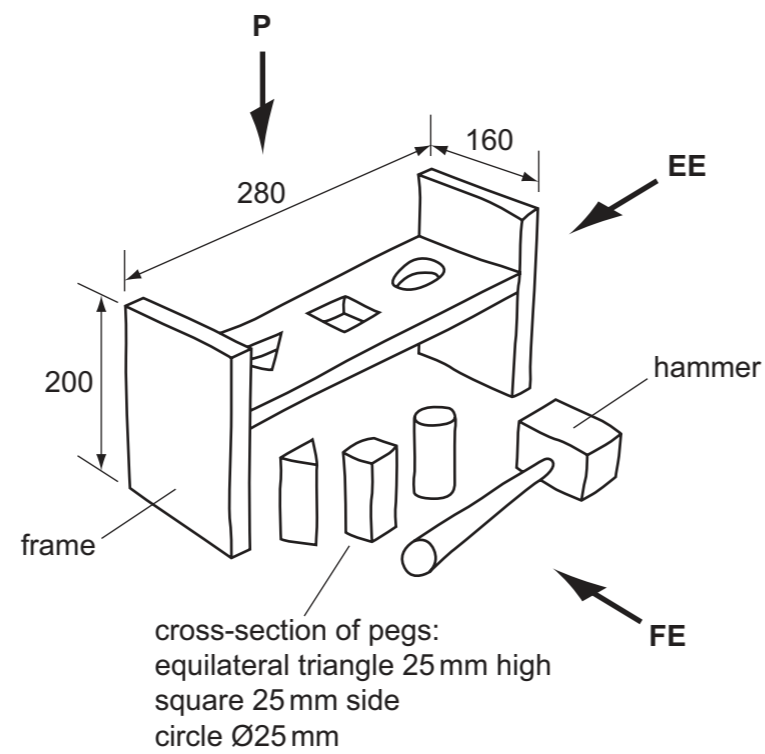

front view

end view

- (d) Orthographic views of the wooden hammer are shown on the right. Draw the full-size **isometric** view of the wooden hammer from the given start point **A**. [8]

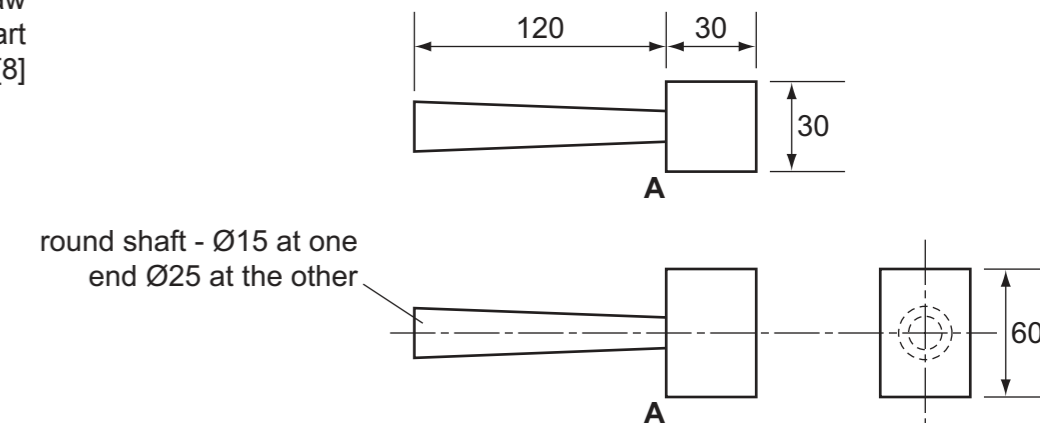

- (e) Sketches of two pegs are shown below. Add rendering to make:
- (i) the square-shaped peg look like wood; [3]
 - (ii) the circular-shaped peg look like plastic. [2]

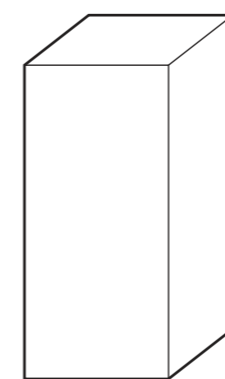

square-shaped peg



circular-shaped peg

- (f) A self-adhesive sticker is to be attached to the end of the frame of the toy. The sticker is to include the word **HARRY**. [2]
- Add the word **HARRY** to the sticker below.

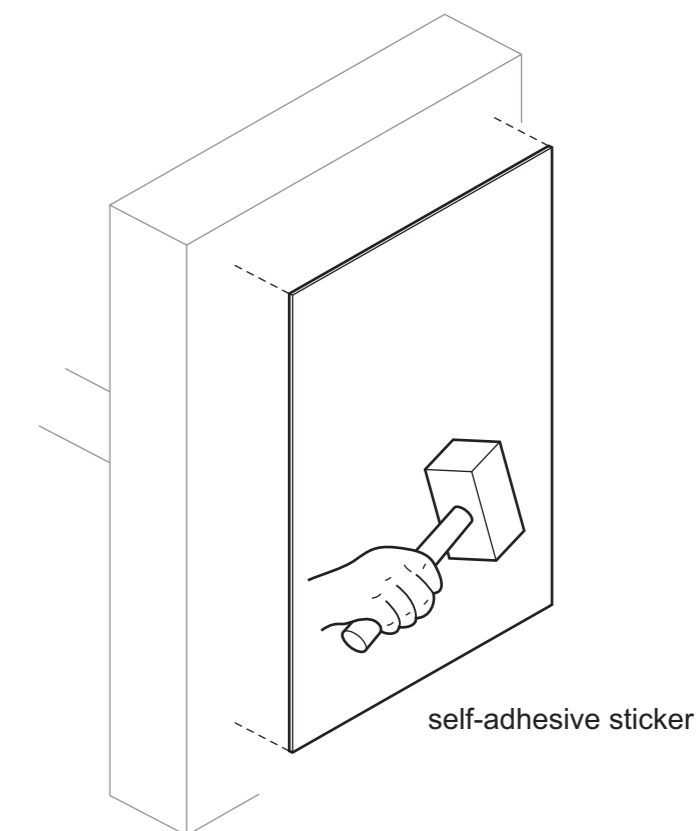

[Turn over

* 4 3 4 2 7 2 6 3 2 5 *

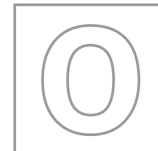

UNIVERSITY OF CAMBRIDGE INTERNATIONAL EXAMINATIONS
 General Certificate of Education Ordinary Level

CDT: DESIGN AND COMMUNICATION
 Paper 1

No Additional Materials are required
 © UCLES 2013

7048/01
 October/November 2013
2 hours 30 minutes
plus 15 minutes reading time
 IB13 11_7048_01/2RP

SHEET 1 OF 2 (SECTION 1)

Write your surname, other names, Centre number and candidate number in the spaces provided.
 Answer **one** question only from Section 1 (Questions 1 and 2).
 Answer **two** questions only from Section 2 (Questions 3 to 6).
 Answer the questions in the spaces provided.
 All construction and projection lines must be clearly shown.
 All dimensions are in millimetres unless otherwise stated.
 The number of marks is given in brackets [] at the end of each question or part question.
DO NOT WRITE IN ANY BARCODES.

Candidate Surname

Other Names

Centre Number

Candidate Number

Examiner's use only

Question 2

A set of cube-shaped children's building blocks is shown on the right. The blocks have letters on them so that children can use them to make words.

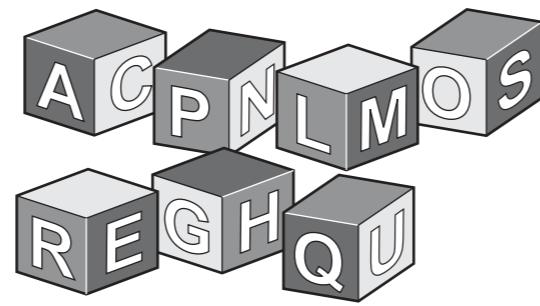

(a) (i) Name the drawing projection method used in the table below to show the building blocks. [1]

..... [1]

| | | |
|---------|-------------------------------|--------|
| | | |
| shading | thick and thin line technique | shadow |

(ii) Complete the drawings in the table above to show the **three** stated methods of enhancing the appearance of the building blocks. [6]

(b) In the space below, complete the estimated two-point perspective drawing of **one** cube-shaped building block. Add a letter **L** to one surface of the building block. [6]

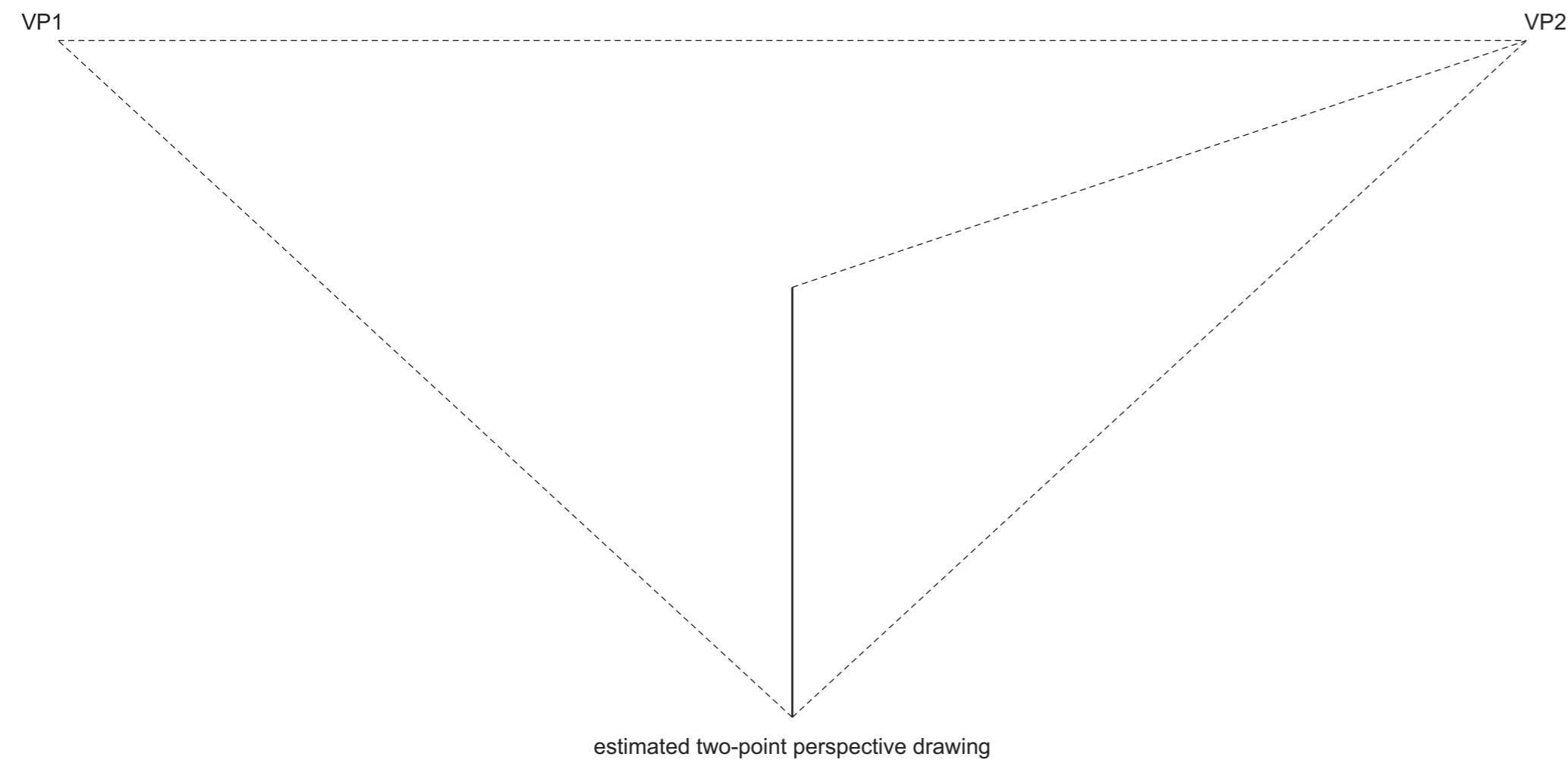

(c) The cube-shaped building blocks are 75 mm square. A set of 24 building blocks is packaged in a rectangular cardboard box.

(i) Complete the table below to show **three** different ways of stacking the 24 blocks ready to be packaged. [5]

| | | |
|--------|--------|--------|
| | | |
| idea 1 | idea 2 | idea 3 |

(ii) In the space on the right calculate the length, width and height of the box required to hold the stack of building blocks shown in idea 1. [3]

size of box:

length =

width =

height =

(iii) Complete the drawing below to show a scale 1:5 drawing of the development (net) required to make the box shown on the right for the stack of building blocks shown in idea 1. Include all fold lines and glue tabs. [9]

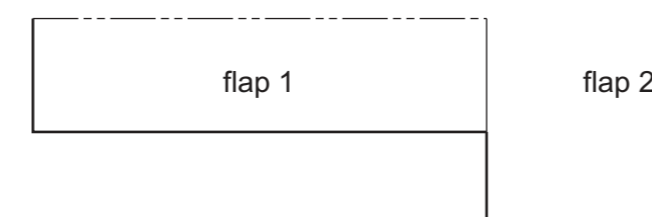
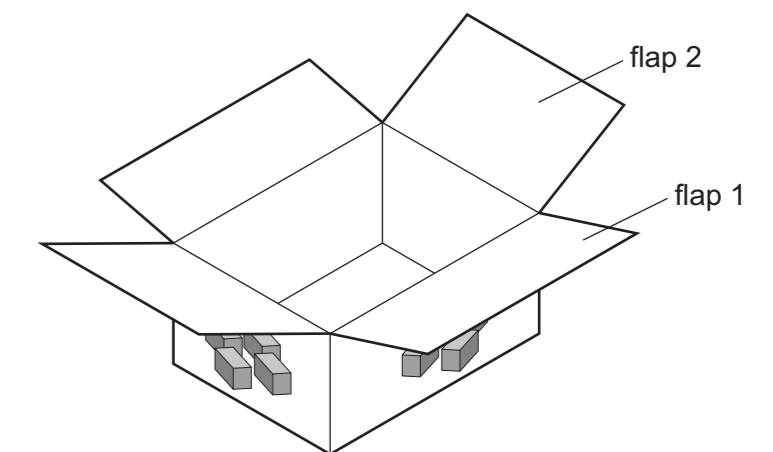

SECTION 2: Answer **two** questions from this section.

Question 3

Sketches of an egg-shaped cam and cam follower are shown on the right. As the cam rotates, the cam follower moves up and down.

(a) In the space below, accurately draw a full-size view of the profile of the cam. [6]

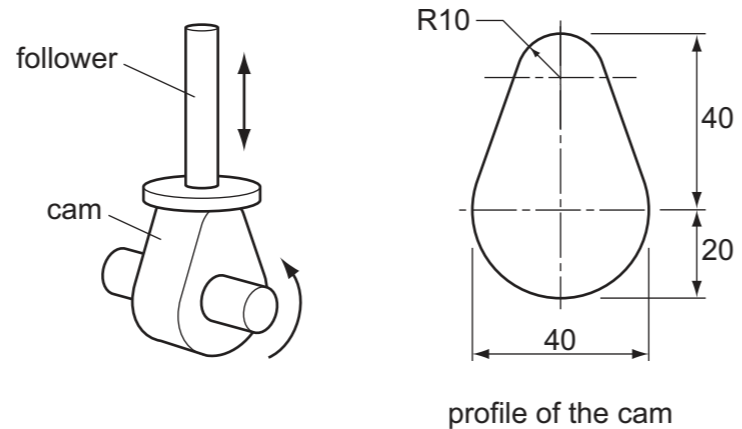
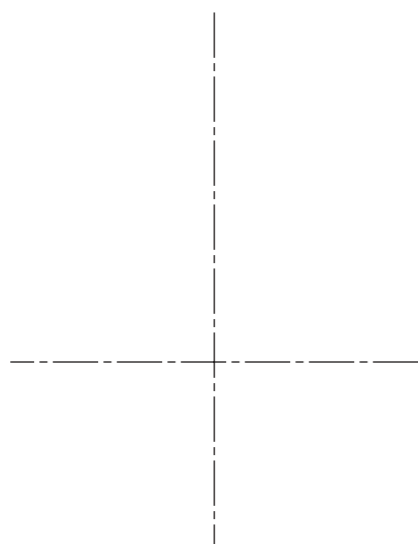

(b) Complete the table below by:

(i) naming the first and last cam profile; [2]

(ii) drawing the profile of the second and third cam. [5]

| | | | |
|-------|-----------------------------------|---|-------|
| | | | |
| | eccentric cam ($\text{Ø}40$) | elliptical cam (major axis 60 mm minor axis 40 mm) | |

(c) Drawings of a pull-along ladybird toy are shown on the right.

The toy is made from a body, an axle and two egg-shaped cams that are used as wheels. In the boxes below:

(i) draw a full-size isometric view of the body of the ladybird toy from the start point **A**. Estimate any dimensions not given; [7]

(ii) sketch an exploded view of the ladybird toy. [5]

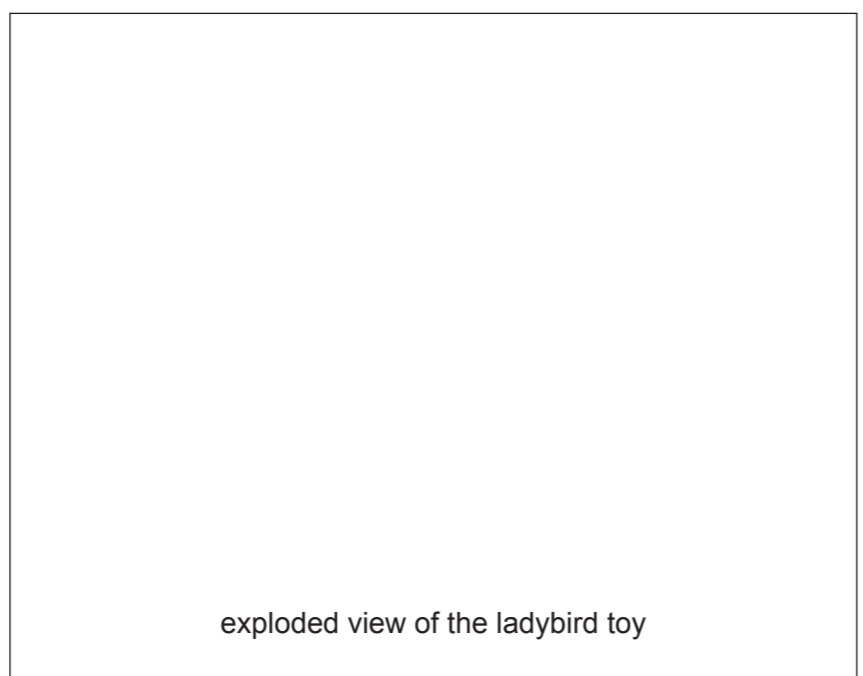
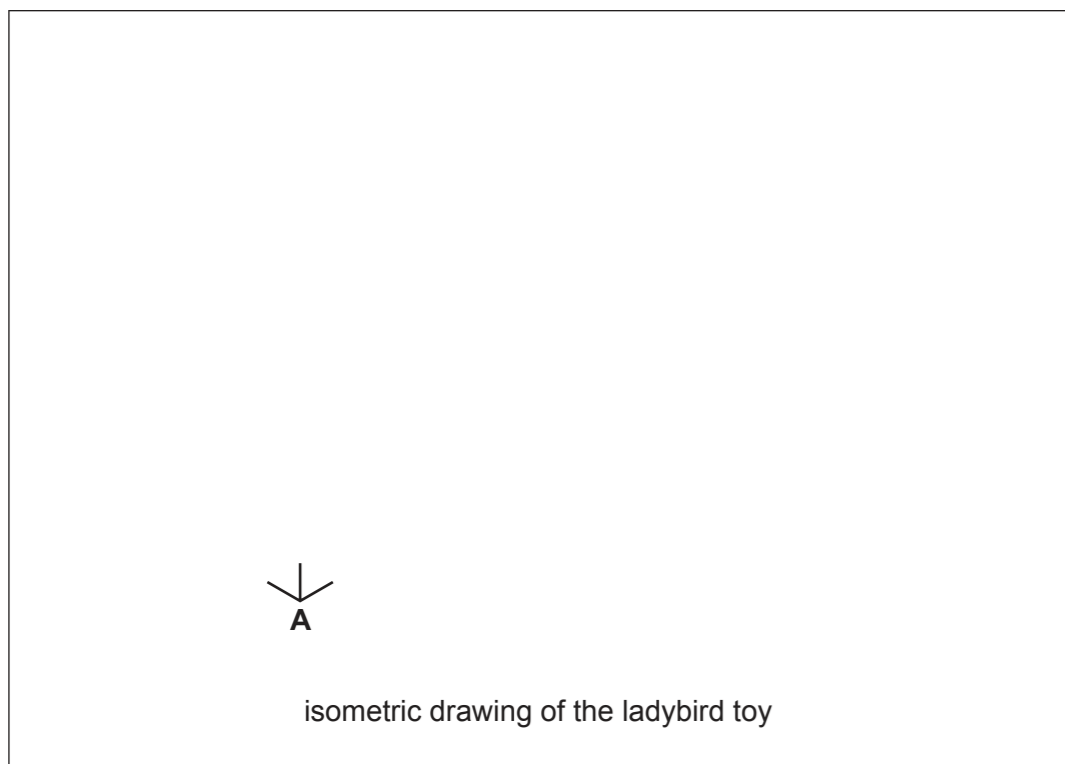
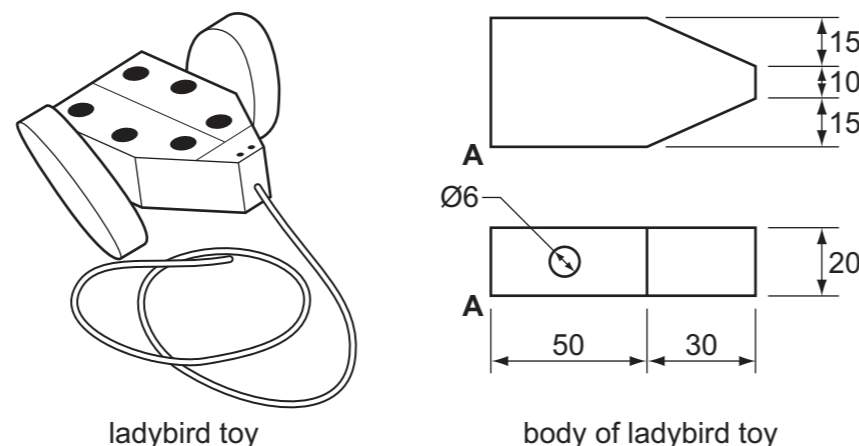

Question 4

A partly completed view of a clock face that is used to help children tell the time is shown on the right.

(a) Complete the drawing of the clock face by adding the centres of eleven more circles that would represent the numbers. [6]

(b) The clock face is made from 10 mm thick foam board and held in an upright position on the clear acrylic stand shown below. Render the stand to look like clear acrylic. [3]

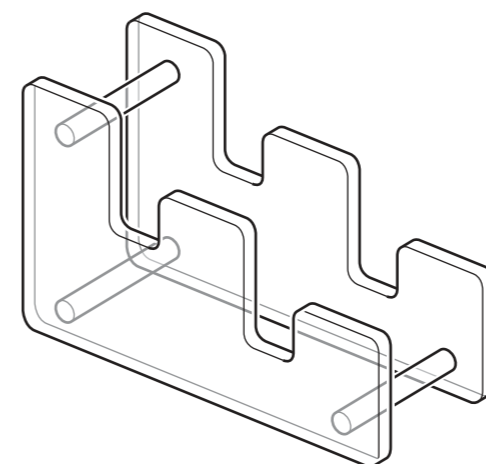

clear acrylic stand

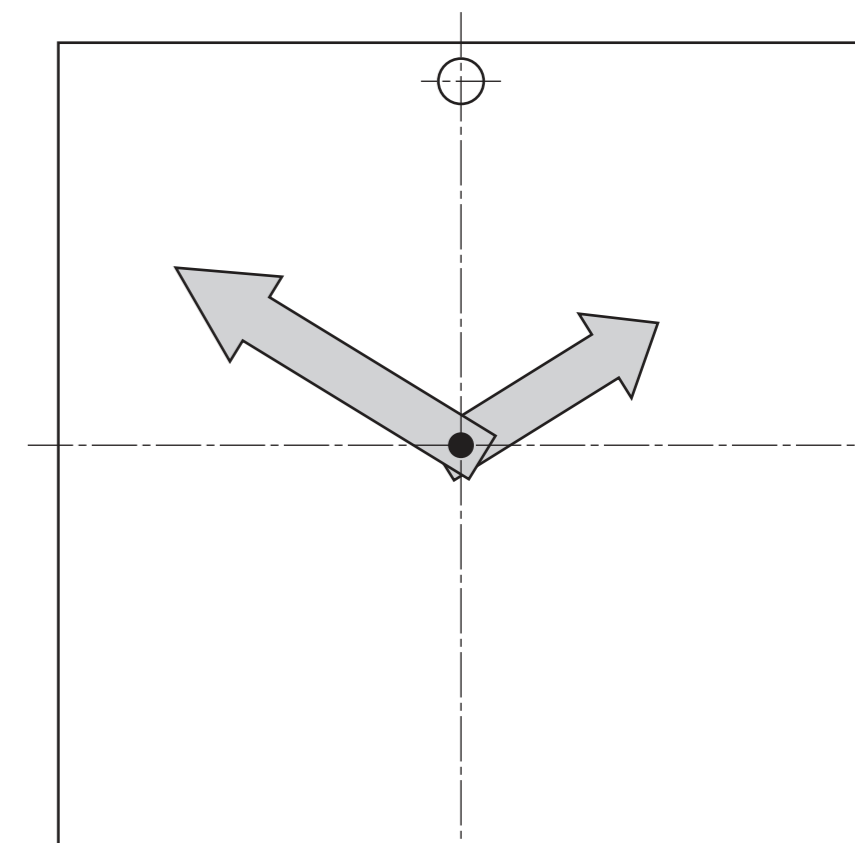

clock face

(c) Colour is to be used to enhance the appearance of the clock face. In the space below, use sketches and notes to:

(i) show a suitable colour scheme for the clock face; [2]

(ii) justify the choice of colours. [2]

(e) An instruction leaflet is included with the clock. The leaflet contains a flow chart with the following stages for assembling the clock.

- 1 Unpack the pieces.
- 2 Stick on the circles.
- 3 Fasten the hands to the correct tightness.
- 4 Place the face on the stand.

Complete the flow chart below to show the stages in assembling the clock. Include a feedback loop to show customers what to do if the hands do not turn. [8]

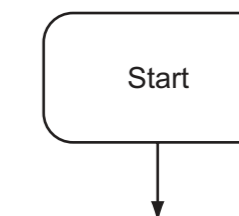

(d) A plastic screw-bolt is used to hold the hands to the clock face so that they can rotate. In the space below, sketch the sectional view of the hands being held by the screw-bolt to the clock face. [4]

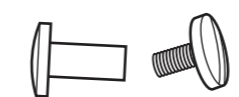

plastic screw-bolt

[Turn over]

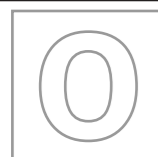

UNIVERSITY OF CAMBRIDGE INTERNATIONAL EXAMINATIONS
General Certificate of Education Ordinary Level

CDT: DESIGN AND COMMUNICATION
Paper 1

No Additional Materials are required
© UCLES 2013

7048/01

October/November 2013

2 hours 30 minutes
plus 15 minutes reading time

IB13 11_7048_01/2RP

SHEET 2 OF 2 (SECTION 2)

Write your surname, other names, Centre number and candidate number in the spaces provided.

Answer **one** question only from Section 1 (Questions 1 and 2).

Answer **two** questions only from Section 2 (Questions 3 to 6).

Answer the questions in the spaces provided.

All construction and projection lines must be clearly shown.

All dimensions are in millimetres unless otherwise stated.

The number of marks is given in brackets [] at the end of each question or part question.

Candidate Surname

Other Names

Centre Number

Candidate Number

